

**THE  
ULTIMATE™  
4-STROKE OUTBOARD**



**SUZUKI**

Way of Life!

SUZUKI DF350A: A REVOLUTION IN INNOVATION



# THE NEW DF350A



## **PROLOGUE | A REVOLUTION IN INNOVATION**

Over the course of our history in the marine industry, Suzuki has been recognized for our 4-stroke seven times by the National Marine Manufacturers Association for having the most innovative new outboards.

This recognition for innovation has also been coupled with many firsts, including the first fuel injected 4-stroke outboards in 1997, the first 250 horsepower 4-stroke outboard in 2003 and the world's first 300 horsepower 4-stroke outboard in 2006.

Join us as we introduce the next milestone in our storied history, the 350 horsepower DF350A, Suzuki's Ultimate 4-Stroke Outboard.











**A FORCE TO MATCH THE POWER OF NATURE AND THE SEA**













































SUZUKI

## HOW THE DF350A CAME TO BE

It's no secret that there is a growing demand for more powerful outboard motors.

These new outboards have, in turn, fueled a move to newer, larger boat designs that previously may have been powered by stern drive or inboard power.

So, as more powerful outboards are introduced, the boats get bigger and as the boats get bigger, outboards are getting more muscular. Suzuki embarked on a major engineering expedition to build the Ultimate 4-Stroke outboard.

### Is The Sky The Limit?

Making more horsepower is no mystery. Increasing displacement, or the use of a turbocharger or supercharger, makes more horsepower. However, larger displacement engines typically burn more fuel, adding weight creates a wide range of problems for boats, and more complex mechanical components create reliability concerns.

On top of all this, boat speed is ultimately limited by hull design, the hydrodynamics of the lower unit and propellers, and how the outboards are mounted.

In developing our new DF350A, we started with a blank sheet of paper, and considered all these factors in our design and engineering.

First, we looked at the traditional single propeller design. A single propeller creates forward thrust, to be sure, but also produces a significant amount of rotational energy as a byproduct. Was there a way we could convert this wasted energy into productive power and improve propeller efficiency?

Secondly, the leading edge of the gear case disrupts the flow of water over the propeller. More power and torque require stronger, larger gears to transfer power from the driveshaft to the propeller shaft. This typically results in a larger gear case – and consequently, more disruption of the flow of water to the propeller. Could we design a lower unit that could house stronger gears and yet minimize the disruption of the flow of water to the propellers?

Suzuki engineers labored mightily through years of computer simulations, trial and error, and on-water testing, to significantly improve the way an outboard converts engine power into underwater thrust.

They have succeeded in this quest – and the result is a revolution in innovation.

**We call it Parting Seas (Geki kanji symbol..)**









## **GEKI: PARTING SEAS**

A Force to Match the Power of Nature and the Sea  
Representing Suzuki's Identity and Heritage  
A Symbol of Our Passion and Commitment  
to the Ultimate in Marine Innovation



## THE COMPRESSION RATIO SOLUTION

As we mentioned earlier, designing an outboard with more power and torque is complicated by the need for lighter weight, better fuel economy and improved reliability. The new V6 DF350A features 4.4 liter displacement, making it the largest displacement V6 on the market today. That being said, how do we develop 80 horsepower per liter and still achieve our design goals?

Our solution was to increase the compression ratio to 12.0:1, the highest compression ratio ever for a production outboard engine. In order to make this work without knocking (a typical problem at this ratio), we developed systems to mix cooler air with well-atomized fuel to provide optimal conditions for complete, and controlled combustion.

## DIRECT INTAKE SYSTEM AND DUAL LOUVER SYSTEM FOR COOL AND DRY AIR

Getting cooler air directly into an engine is no problem on land, but on water it's a different story. Our initial attempts at direct intake resulted in water getting into the mix – not a good thing. Fortunately, our engineers are good at lateral thinking. Riding a fast-moving train on a rainy day, one of our engineers noticed the water particles streaming across the window. That was it, at speed, water particles could be directed, trapped and drained away.

Work immediately commenced on increasing the intake flow to convert water vapor to particles and then designing blades to capture and deflect those particles away from the intake flow. After countless trials, we developed a Dual Louver System that resulted in eliminating water intake, even in the face of the most severe on the water testing.

The Dual Louver System incorporates a double shield of blades, each one designed in a dog-leg shape. The outer row of blades removes the spray from the boat and the inner louvers capture and drain the remaining mist.

As a result, intake air temperature is free of moisture and no higher than 10° above ambient. **This solved the first challenge.**

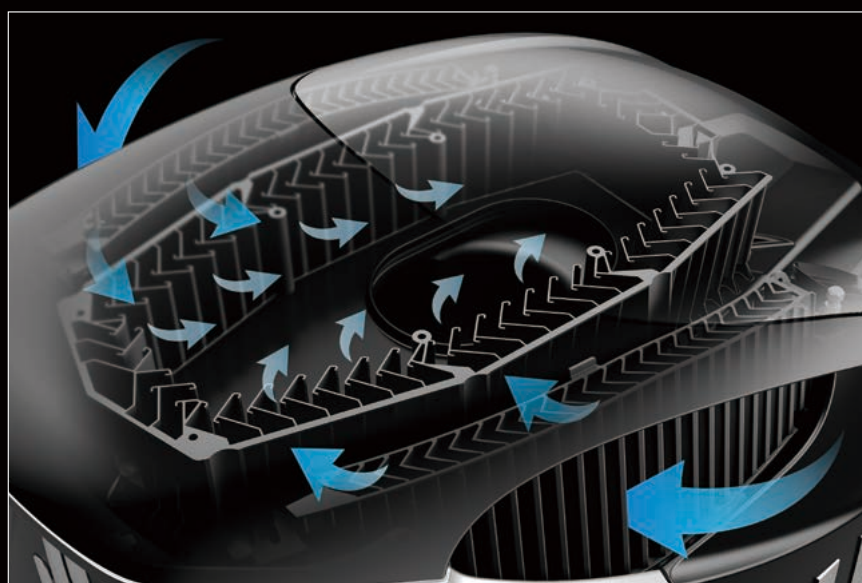

**SUZUKI DUAL LOUVER SYSTEM**

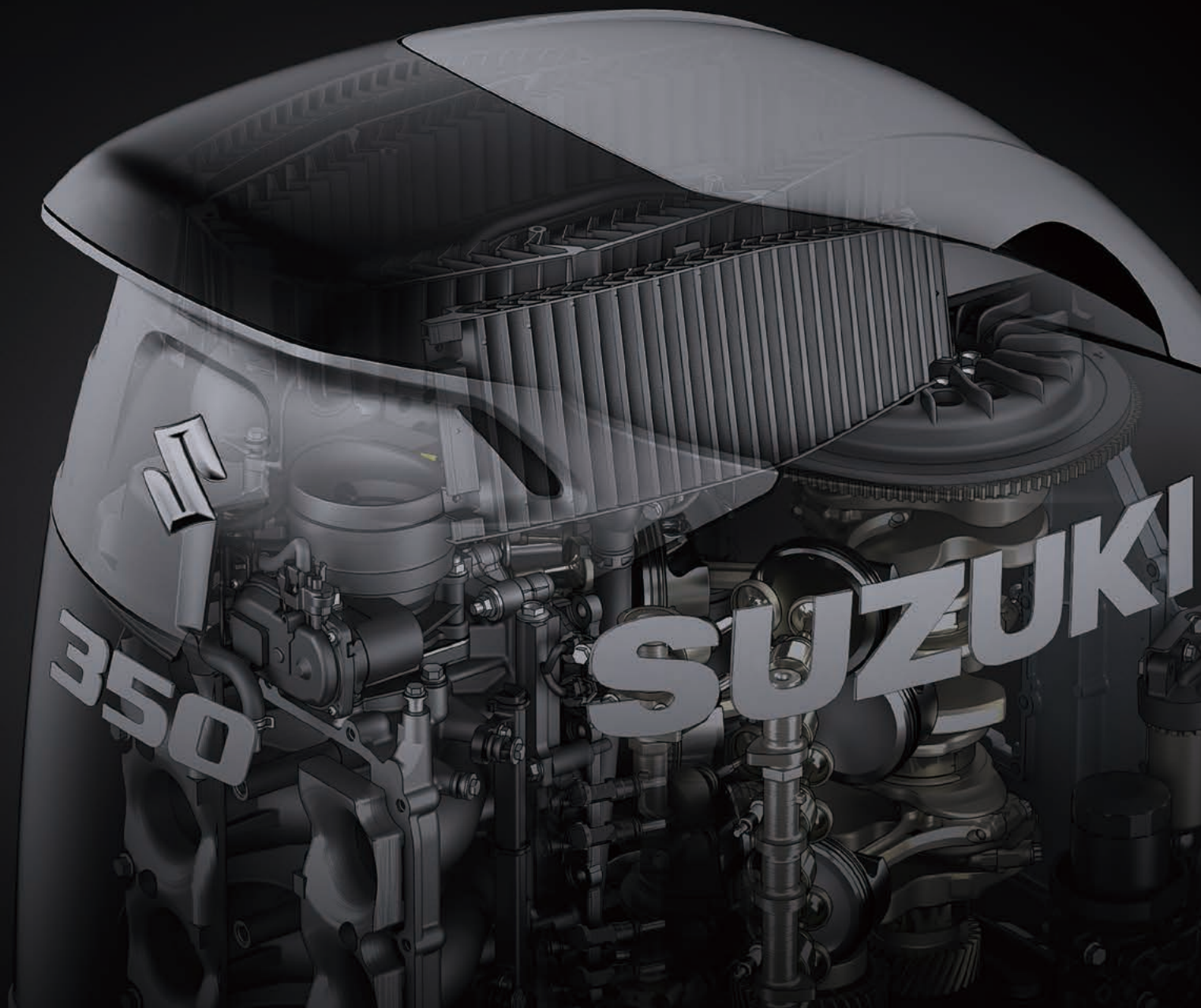

## DUAL INJECTORS FOR BOTH COOLING AND POWER

As we mentioned earlier, our decision to use a 12.0:1 compression ratio provided us with the power we wanted, but also introduced several design challenges. With the Dual Louver System and the Direct Intake System, we got the dryer and cooler intake air that we needed. Next was fuel delivery.

Injecting fuel does two things, it atomizes the fuel and, incidentally, it cools the cylinder. Cooling the cylinder was an important factor in minimizing knock. To achieve the power we wanted, we needed to inject 100% of the fuel into the cylinder at once, at a precise time, and at a precise angle to both cool the cylinder and to allow combustion in the combustion chamber.

We developed a new Dual Injector System to accomplish these objectives. Using two smaller injectors provided the precision we needed, plus it achieved improved atomization. In fact, we were able to increase output by 3% without causing knocking.



**DUAL INJECTOR**

## THE HUMBLE PISTON MEETS ADVANCED TECHNOLOGY

It's hard to imagine the life of a piston. It repeatedly advances only to get blown back to where it started. With our higher compression ratio, we asked more of the piston than ever before. Not only did the surface have to withstand greater forces, the connecting rod and hardware had to be strengthened, as well.

To help the piston withstand the added lateral pressure, we switched from the standard surface texture treatment to shot peening. Shot peening creates fine dimples on the surface that evenly distribute the pressure created during combustion. It's a more expensive, and far more involved manufacturing process, but one that makes it possible to create a piston worthy of the "ultimate" title.







## DEVELOPMENT OF SUZUKI'S FIRST CONTRA-ROTATING PROPELLER

With the engine challenges met, Suzuki engineers moved to the lower unit.

Again, the real world imposed itself on the theoretical thinking of the engineers. After years of outboard design, Suzuki engineers knew that the shape of the lower unit and the design of the propeller would have a critical impact on performance. The increased power of the new engine required more powerful gears, and more powerful gears were typically larger. Larger gears would require a larger gear case to spin a larger propeller. A larger gear case created more resistance underwater which slowed the boat and negatively affected the added power of the engine.

After considering alternatives, an innovative idea was proposed that would solve these problems: design a contra-rotating propeller system. The contra-rotating propeller would certainly provide more "grip" underwater, and because contra-rotating propellers distribute the engine torque evenly over two propellers, the torque per propeller decreases and gear diameter can be reduced. A reduction in gear diameter could then lead to the design of a smaller, more hydrodynamic gear case.

Of course, several design challenges were encountered along the way that required a lot of creative problem solving. For example, the initial contra-rotating propellers used the same bushings as our single propeller. Under load, these rubber bushing compressed and the propellers actually hit against each other, requiring the further analysis and the eventual development of a new bushing that would keep the propellers separated.



**SUZUKI DUAL PROP SYSTEM**

## PROPELLER BLADE DESIGN

Suzuki engineers also explored using a four-blade propeller in front of a three-blade propeller, a set-up found on other contra-rotating propeller designs. This arrangement did not run as expected, however, and a new three-blade/three-blade propeller set up was developed to provide improved performance in both the test tank and on the water. In fact, this new set up provided not only the highest recorded speeds, but also delivered incredible acceleration, even under heavy load and at high rotation speeds.

The design of the actual propeller blades was next on the list. Given the fact that engine torque was distributed over 6 blades instead of just three, the initial thinking was that the propeller blades could be thinner. In testing, however, it was discovered that the rearward propeller was sometimes running in both air and water when the engine was trimmed. Under these conditions, the thinner propeller blades were under tremendous stress. Suzuki engineers studied the cross-sectional shape of the propeller blade as well as propeller geometry, identified any weak points and strengthened the overall design of the propellers.





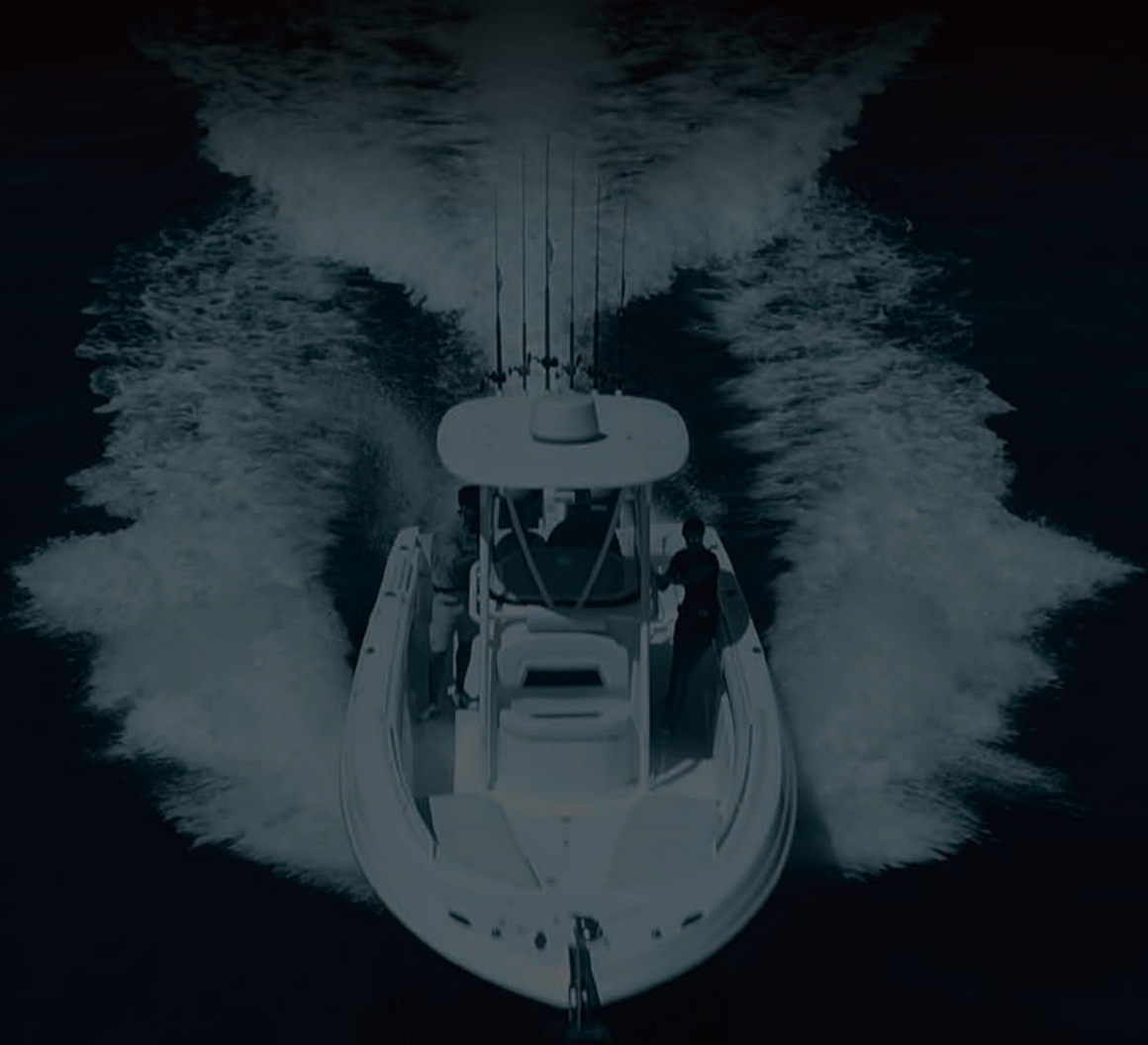
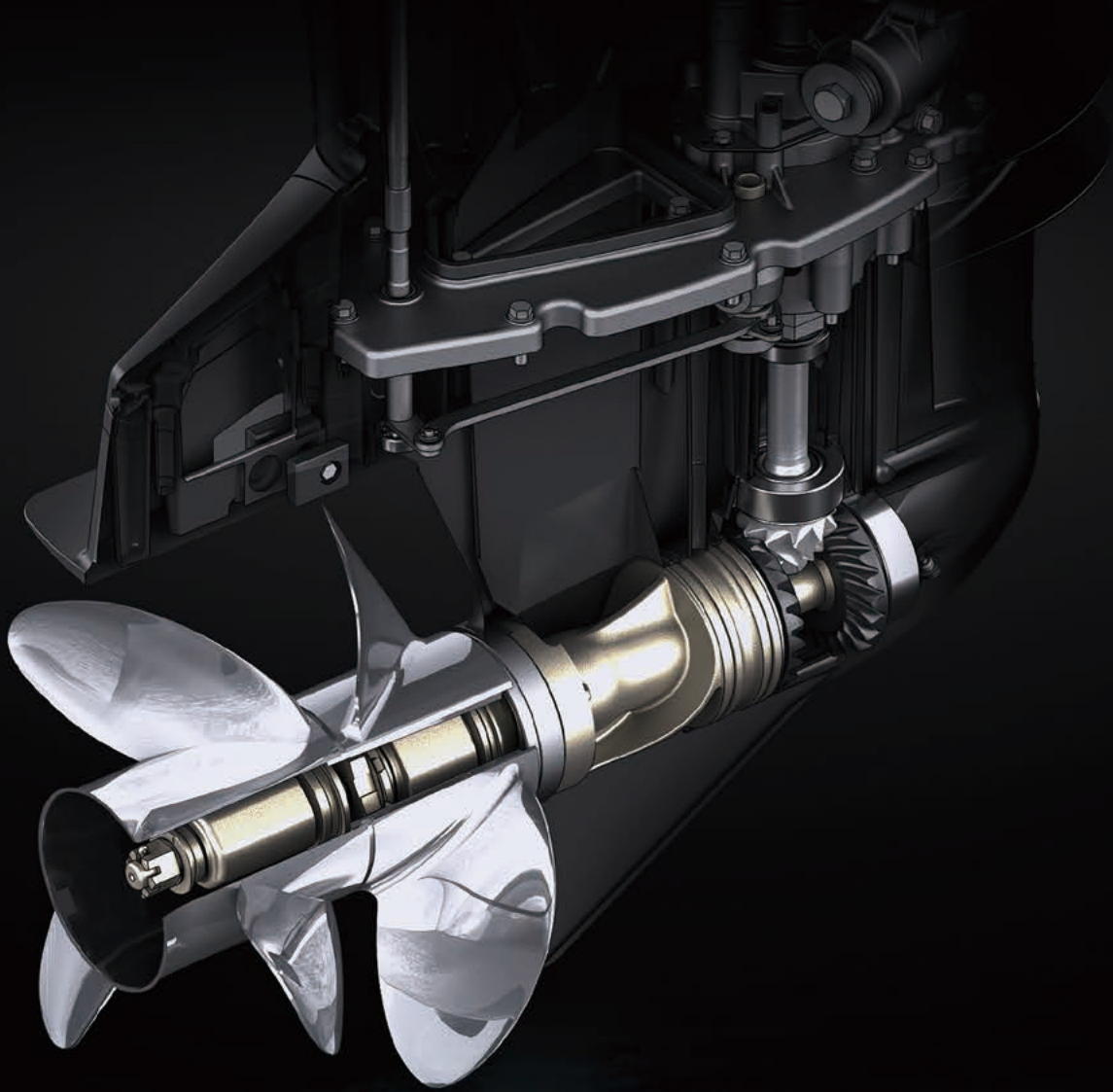

## GEAR CASE DESIGN

Designing the actual shape of the gear case was another significant challenge. Top speeds, even with the new contra-rotating propeller, were not up to expectations. Analysis revealed that cavitation voids around the gear case were still causing excessive resistance. While Suzuki engineers had extensive experience in designing gear case profiles, these new, faster speeds presented new challenges. After many late nights, repeated simulations using computational fluid dynamics (CFD) and countless test drives, a breakthrough design was developed that both minimized resistance and provided the most efficient flow of water to the propellers.

### DUAL WATER INTAKES

Designing the shape of the gear case also required repositioning the water intakes. It was important to arrange the main and sub intakes as far apart from each other as possible, and to design them to ensure a reliable amount of cooling water, especially at high speeds. On the DF350A, the best results were achieved when the main intake was positioned at the front of the gear case, with the secondary intake located just above the skeg.

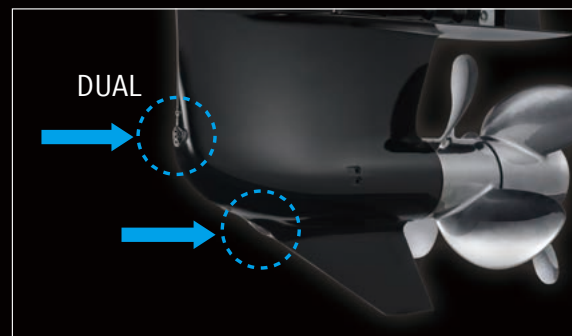

**DUAL WATER INLET**

### GOING BACKWARDS

With six blades rotating, the contra-rotating propeller produces a strong reverse thrust. So strong, in fact, that the engineering team had to change the gear material and add the heat treatment for the contra-rotating propellers to endure the added thrust and inertial mass. A larger gear was out of the question, as the gear case design was completed.

The design process is never easy, and the DF350A has taken Suzuki to a new level of speed and performance. In spite of the many design challenges, Suzuki engineers have continually worked to find the “ultimate” solution that will provide its customers with exciting performance and solid reliability. Every member of the team contributed to the success of this new outboard and you will experience the results of their hard work every time you start the Ultimate 4-Stroke Outboard.

### EFFICIENCY AND BALANCE USING MULTIPLE OUTBOARDS

Normally, when using multiple outboards a combination of standard and counter-rotating engines is mounted. Suzuki Selective Rotation, available on our AP series outboards, eliminates the need for different models, as any model can be easily programmed to run in either direction. The DF350A's contra-rotating propeller technology takes this process one step further by eliminating steering torque and maximizing true and straight propulsion forces.





# VOICE OF DEVELOPERS



**Katsuhiro FUKUDA**

*Chief Engineer*

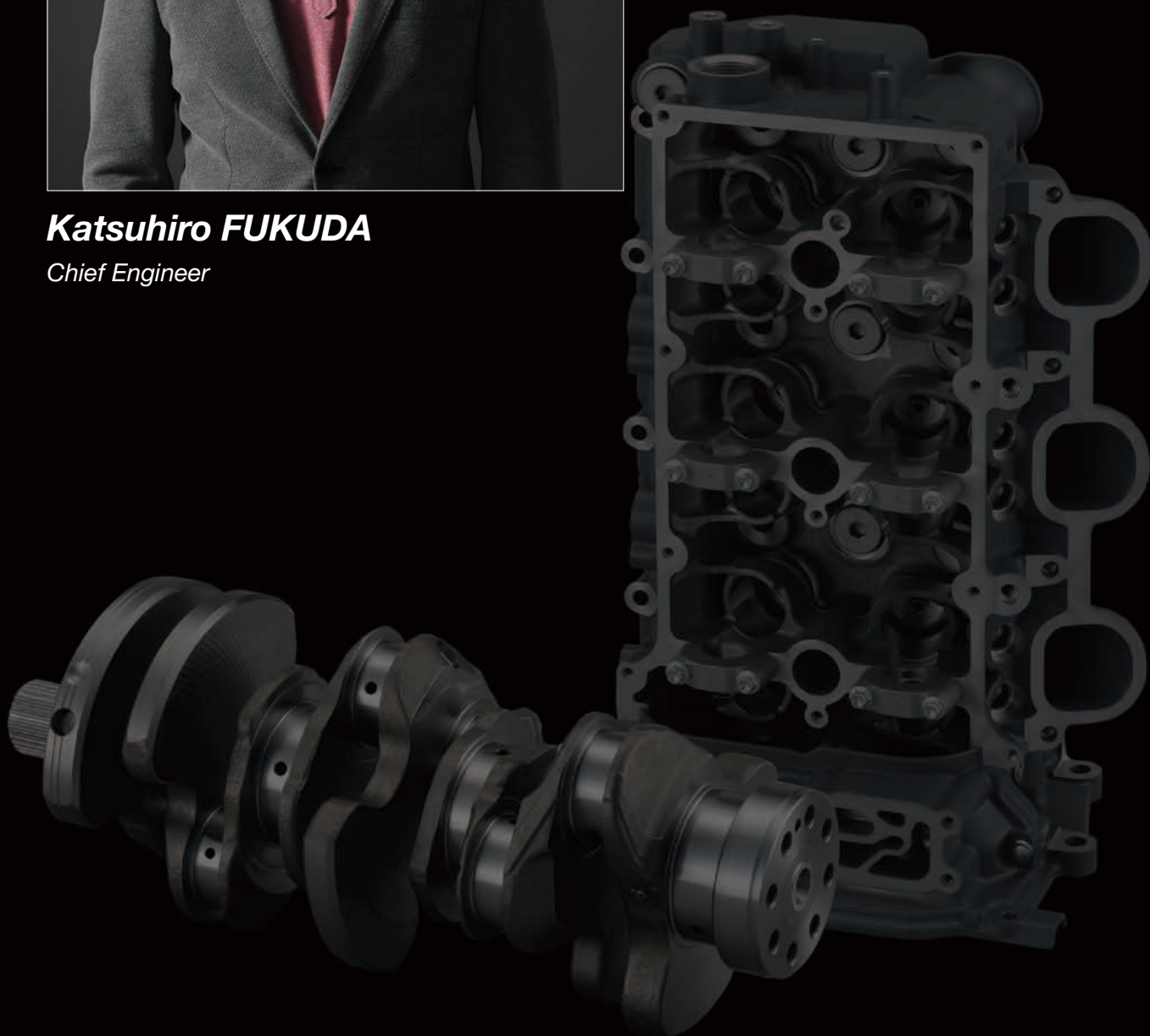







**Atsushi OHTANI,**  
*Product Designer*

Innovative, aggressive, and sporty design.

Dynamic design that you can recognize as a Suzuki outboard at a glance. Quality design that is suitable for the flagship model and gives you the joy of possession. These were the most important factors in developing DF350A.

As for the details of its design, we expressed the characteristics of Suzuki outboards with the dynamic silhouette of a slant shape with an obliquely scraped forehead and raised rear end. And as a characteristic feature, we designed the side openings to show the vertical fins of Suzuki Dual Louver System, our original air-water separator.

Taking each character line and part parting line as an organic and emotional character, we have succeeded in expressing the elegance with these long-stroke lines flowing beautifully and three-dimensionally. We also created a joyful atmosphere with two-tone color painting of nebular black (or white) and silver.

The overall shape is designed to make users imagine speed even with the outboard alone while considering the sense of harmony with the boat. DF350A is designed with the goal of being chosen also for its beauty, featuring outstanding design beyond that of a mere power unit.

We have succeeded in achieving both the ultimate compactness and superior design without unnecessarily increasing the volume.



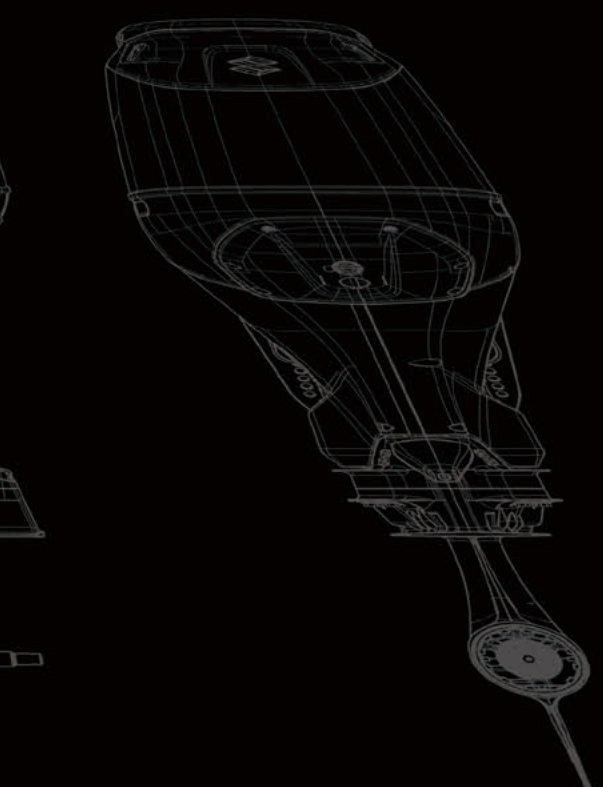

# VOICE OF DEVELOPERS

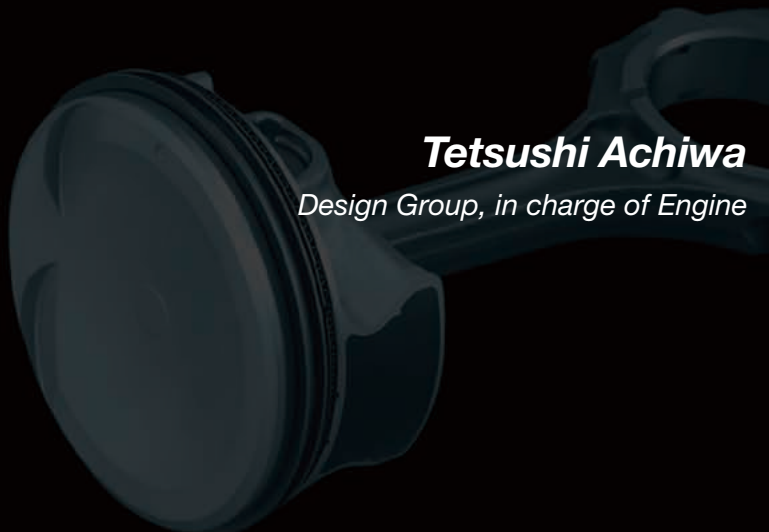

## **Tetsushi Achiwa**

*Design Group, in charge of Engine*



"Form follows function."

This is one of my favorite words.

The lower unit of the DF350A is a realization of these words. A gentle, elegant periphery of the shell, an outstandingly tough and strong material surface, and a contra-rotating propeller that helps them harmonize with each other. Each of them has its own function and gives it shape.

The DF350A is our next step for specification without counter-rotation after the Suzuki Selective Rotation, which was developed in 2011. It was a very valuable experience for lower unit designers to be able to challenge the contra-rotating propeller specification as the next step following Suzuki Selective Rotation. Development of a new technology is always a series of failures, and we cannot overcome failures with only conventional design methods.

Why does new technology fail? How can we adopt new technology? We noticed one thing while repeating failures.

It was that we cannot adopt new technology without complete understanding of conventional technology.

And to have complete understanding of conventional technology, we must keep asking ourselves, "How should it really be?".

The "form" mentioned at the beginning is the result of repeatedly asking "How should it really be?" for each function.

The DF350A is packed with new technologies in addition to conventional technologies that have come back to join.

Who will be the customers feeling the DF350A?

As an engineer, I cannot help but be excited.



## **Jiro Saiga**

*Design Group, in charge of Cowling*





At the first trial production of DF350A after obtaining some prospects through repeated preliminary tests using DF300AP as the base, the output performance was far from that we had expected. As a result of aiming at the high compression ratio of 12.0, knocking inevitably occurred, and therefore we could not achieve the ideal high output. To achieve 350 horsepower with a small displacement, the compression ratio of 12.0 is indispensable, and also there was a concept of a compact engine. So, we could not change the layout largely. Then, we returned to the starting point and thought of reconsidering the design of the combustion chamber. We repeated CAE in order to increase the amount of air agitated in the chamber while increasing the air flow for combustion, and finally reached the current shape in which the piston top protrudes to the head side. Since the shape was unlike any Suzuki had experienced before, we had no experience about the manufacturing and quality control methods, and therefore we faced disapproval from the relevant parties. So, we explained over and over and eventually convinced them that the shape was necessary for achieving the "ultimate" performance, and had them devise the manufacturing process so that it can be adopted to mass production. Even if the propulsion efficiency gets better with a contra-rotating propeller, the target performance cannot be achieved if the engine output is low. Moreover, unless the engine outputs the target output, we cannot even start the evaluation tests of propulsion functions and operability using actual outboards. We made improvements day by day while feeling heavy pressure on engine improvement from the designers of other parts as well as the persons in charge of experiment. This high performance engine is the result of squeezing wisdom to meet the expectations from the surroundings.



## **Shuichi Sugiyama**

*Design Group, in charge of Lower Unit*

We want more horsepower. To increase horsepower with the cover, it is necessary to supply the outside air to the engine while maintaining the temperature. For that purpose, we adopted the direct intake system. We knew how one of our competitors had been evaluated after adopting a direct intake system. We were prepared for difficulty. We must never allow a single drop of water into the engine. In order to achieve absolute water separation, we adopted the dual louver system consisting of inner and outer louvers arranged parallel to each other with dog-leg shaped louver blades. The outer louver removes water drops sprayed by the hull, and the inner louver removes the finer mist. The dog-leg shaped louver blades increase the intake flow rate as much as possible to hit against blades the water drops and mist contained in the intake air and thoroughly remove them.

The shape of the outer louver, which has never existed before, has a strong influence on the appearance of DF350A. In order to satisfy the horsepower and absolute water separation while making the appearance of DF350A more impressive, we modified the design model over and over again. By making and examining various prototypes of different angles and intervals of the blades, we successfully achieved a satisfactory shape. In order to ensure stable louver performance, we had decided to make each louver with a single part. We created a digital 3D model considering the requirements for manufacturing.

We've never seen such a part. Can we really mass-produce it?

We had a meeting with a molder and mold manufacturer feeling anxious. Sure enough, they asked us, "Please show me the reference parts". Our answer was, "We have never seen one." The mold manufacturer got serious. We covered everything from designing the actual part to designing the mold. We are satisfied that we were able to design a truly genuine piece.









# OUR PROVEN TECHNOLOGIES ARE BACK IN THE DF350A



## SUZUKI'S LEAN BURN CONTROL SYSTEM

Suzuki's innovative Lean Burn Control System was first introduced on the DF90A/80A/70A to great acclaim. The system predicts fuel needs according to operating conditions, allowing the engine to run on a leaner, more efficient air-fuel ratio. It delivers its benefits over a wide operating range, providing significant improvements in fuel economy from low-speed operation into the cruising range. In combination with Suzuki Precision Control electronic throttle and shift system, the operator can precisely, and smoothly, increase or decrease engine RPM for significantly improved fuel economy.



## QUIET OPERATION

Suzuki outboards have long been noted for their quiet operation. In fact, they run so quietly that some users have thought the engine was switched off. To ensure this same level of quiet operation, DF350A is fitted with a resonator on the intake manifold. Often overlooked as a noise source, air drawn into the intake manifold

at high velocities can generate a harsh noise. Adding the resonator reduces such noise, keeping the engine operation exceptionally quiet.

We have taken sound quality into consideration over the entire speed range and both skipper and passengers alike will be impressed with both the quietness and engine sound, especially when idling or trolling.



## LARGE REDUCTION GEAR RATIO (Powerful Propulsion)

Suzuki's sophisticated technologies deliver a large reduction gear ratio.



## OFFSET DRIVESHAFT

Suzuki outboards are among the most compact outboards in their respective classes. That's due in part to Suzuki's proven offset driveshaft system. This design places the crankshaft in front of the driveshaft through the use of intermediate gear reduction. In addition to providing an increase in power performance and adding to the compactness of the outboard, this system moves the outboard's center of gravity forward, resulting in better weight distribution and balance, more directional stability, and less vibration.



## 2-STAGE GEAR REDUCTION

The DF350A outboard also incorporates a 2-Stage Gear Reduction which results in a large reduction gear ratio. It delivers powerful torque for quick acceleration and great top-end speed.

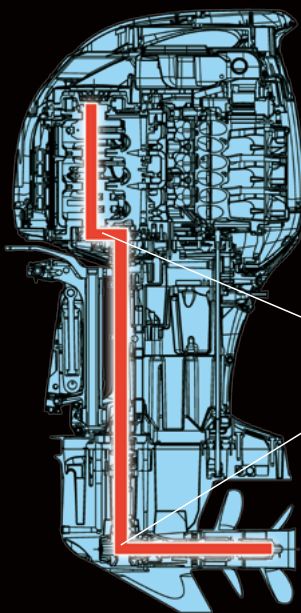

1st Stage Reduction  
32:40=1.25

2nd Stage Reduction  
12:22=1.83

Total Gear Ratio=2.29:1





## SUZUKI'S ADVANCED TECHNOLOGY DELIVERS THE UTMOST IN PERFORMANCE VVT (Variable Valve Timing)

Suzuki's engineers designed the 4.0-liter V6 engine with an aggressive cam profile that delivers maximum output and performance at high rpm. In coupling this cam profile with

Suzuki's advanced Variable Valve Timing (VVT), the DF350A delivers the additional torque that outboards need for accelerating in the low to mid-range. VVT achieves this by adjusting the timing of the intake valves, allowing them to open before the exhaust valves are fully closed, creating a momentary overlap in the timing where both sets of valves are open. Using VVT, this overlap can be increased or decreased by altering intake timing with the camshaft resulting in optimum timing for low and mid-range operation.

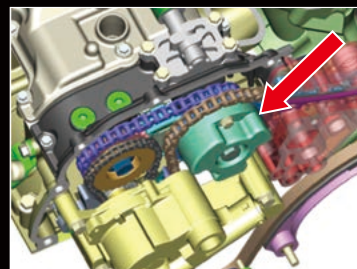

## SUZUKI PRECISION CONTROL (Electronic Throttle and Shift Systems)

This technologically advanced system is a computer-based drive-by-wire control system that eliminates the friction and resistance of mechanical control cables. Operation is smooth and precise with crisp, immediate shifting that is most evident in the low rpm range and when maneuvering around the marina and in close quarters. The system is configurable for single, twin, triple, or quad installations, and for dual stations.

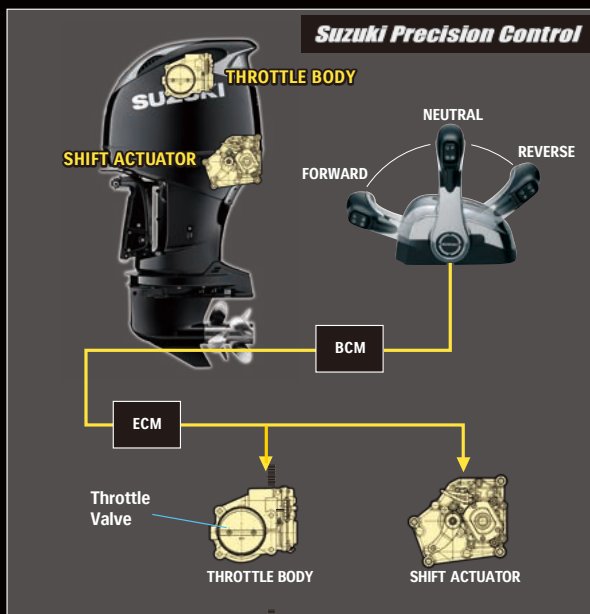

## SUZUKI TROLL MODE SYSTEM

Suzuki's Trolling Mode system provides finer control over engine speed at low rpms to keep your boat moving at a constant speed while trolling. When the system is engaged, revs are controlled with an independent control switch that adjusts engine revs in 50rpm increments over a range spanning from idle to 1,200rpm. The system includes a control switch, which can be mounted nearly anywhere on the console, and a tachometer, and is compatible with Suzuki's SMIS digital gauges or the dual scale analog gauges.



## SELF-ADJUSTING TIMING CHAIN

The timing chain runs in an oil-bath, so it never needs lubricating, and is equipped with an automatic hydraulic tensioner, so it remains properly adjusted at all times. Simple, effective and maintenance-free.





# OUR PROVEN TECHNOLOGIES ARE BACK IN THE DF350A

## HIGH OUTPUT ALTERNATORS

Today's boats are equipped with a wide array of electronics that demand an ample flow of power to keep them running. With that in mind, Suzuki engineers have equipped the DF350A with an alternator that produces a majority of its maximum 54A (12V) output with the motor running at a low 1,000 rpm—enough power for most circumstances.

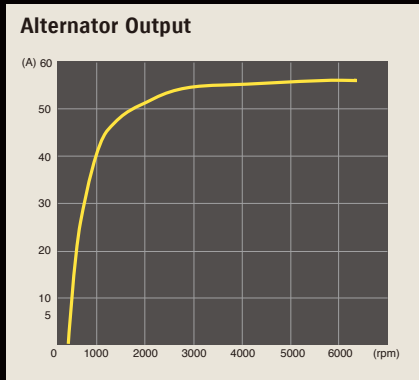

## KNOCK SENSOR

The knock sensor monitors combustion to provide the ECM with information needed for precise management of engine timing for optimum performance. In addition to maximizing power output, the system also helps increase engine durability.

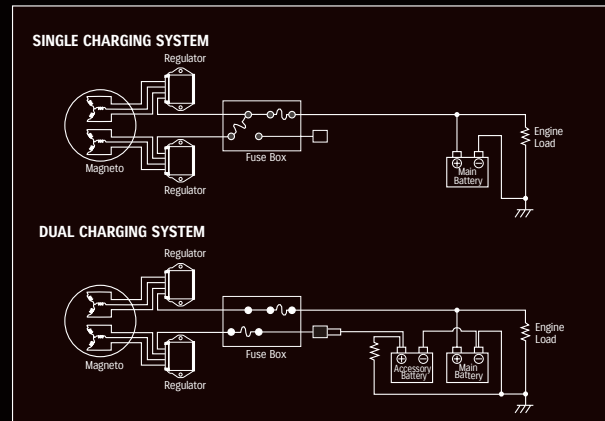

## CONVENIENT DUAL CIRCUIT CHARGING SYSTEM

The DF350A incorporates a dual circuit charging system that can be adapted\* to accommodate the dual-battery configurations often used on large boats. When used in this configuration the system is designed to charge both the main and auxiliary batteries simultaneously but on independent circuits. With this you can drain down the accessory battery powering your electronics and still have a fully charged main battery for starting the motor.

\*Utilization of this system requires the purchase of an optional wiring harness.





## FUEL COOLER

The cooler fuel is more dense, and dense fuel delivers more performance. A fuel cooler in the DF350A's fuel delivery system cools the fuel before it enters the engine, resulting in better combustion and improved performance.



## CLEANER, MORE EFFICIENT OPERATION

Suzuki's advanced four-stroke engines conform to the emissions standards set forth by the Recreational Craft Directive (RCD II)- Directive 2013/53/EU of the European Parliament and of the Council, and have received three-star Ultra Low Emissions ratings from the California Air Resources Board (CARB).

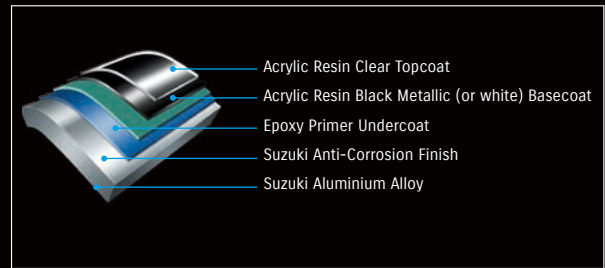

## SUZUKI'S ANTI CORROSION FINISH

Suzuki's Anti-Corrosion Finish is specially formulated to increase the durability of the engine and help protect parts of the aluminum exterior that are constantly exposed to fresh and saltwater. This advanced finish offers maximum bonding to the outboard's aluminum surface, creating an effective treatment against corrosion.





# SPECIFICATIONS

MODEL	DF350A	
RECOMMENDED TRANSOM HEIGHT mm (in.)	X : 635 (25)	XX : 762 (30)
STARTING SYSTEM	Electric	
WEIGHT kg (lbs.) *1	X : 330 (727)	XX : 339 (747)
ENGINE TYPE	V6 - 55° DOHC 24-Valve	
Valve Train Drive	Chain with Variable Valve Timing	
FUEL DELIVERY SYSTEM	Electronic Fuel Injection	
NO. OF CYLINDERS	6	
PISTON DISPLACEMENT cm <sup>3</sup> (cu.in.)	4,390 (267.9)	
BORE × STROKE mm (in.)	98 (3.74) × 97 (3.82)	
MAXIMUM OUTPUT kW (PS)	257.4 (350)	
FULL THROTTLE OPERATING RANGE rpm	5,700 - 6,300	
STEERING	Remote	
OIL PAN CAPACITY ℓ (U.S./Imp. qt.)	8.0 (8.5)	
IGNITION SYSTEM	Fully-transistorized	
ALTERNATOR	12V 54A	
ENGINE MOUNTING	Shear Mount	
TRIM METHOD	Power Trim and Tilt	
GEAR RATIO	2.29:1	
GEAR SHIFT	F-N-R (Drive-by-Wire)	
EXHAUST	Through Prop Hub Exhaust	
PROPELLER SELECTION (Pitch)** All propellers are the 3-blade type	FRONT: 3×15 1/2×19.5-31.5 REAR: 3×15 1/2×19.5-31.5	

\*1: Dry Weight: Including battery cable, not including propeller and engine oil.  
\*2: Please inquire at your local dealer for details of the propeller.

# DIMENSIONS

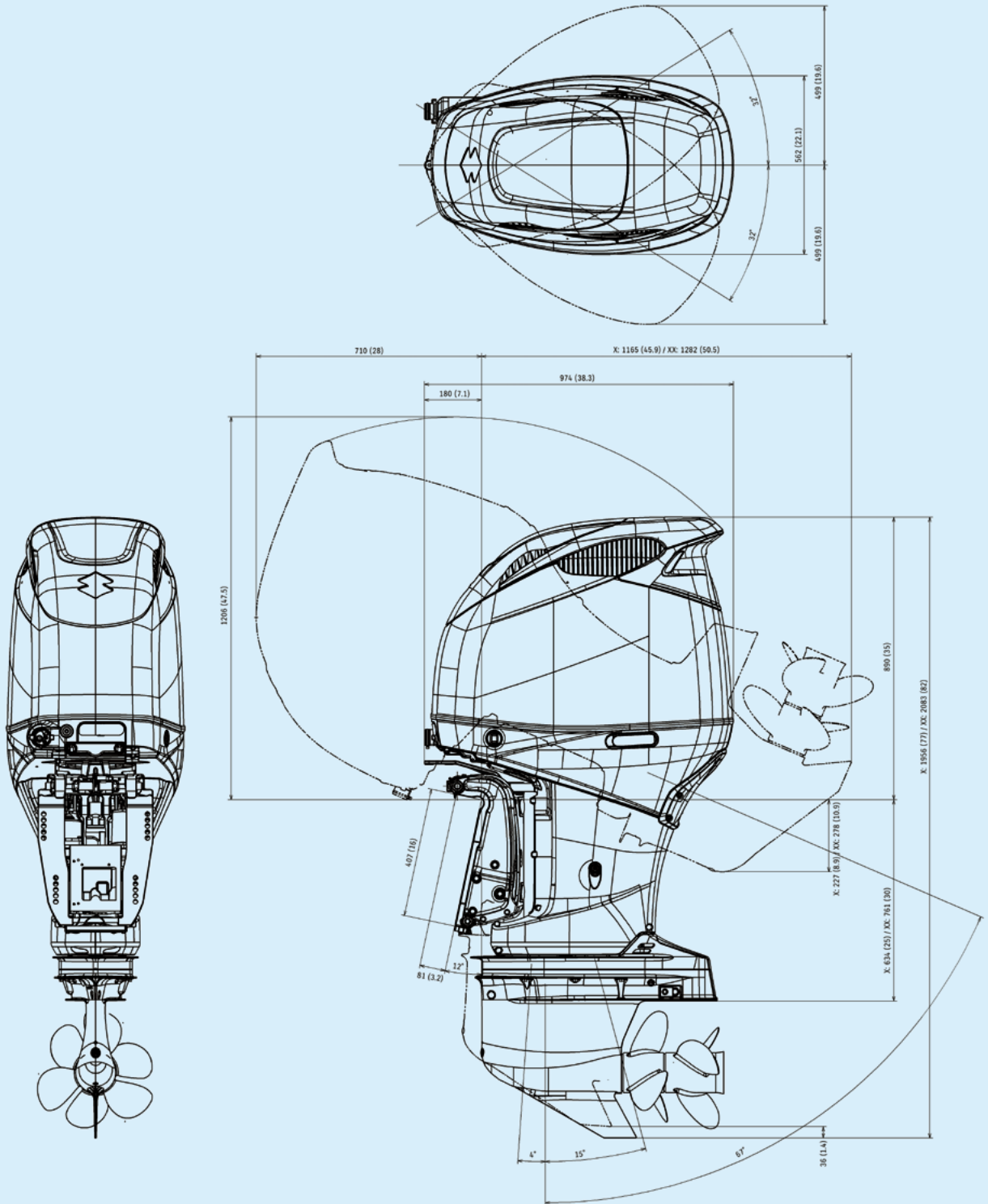

Unit: mm (in)



## EPILOGUE

This is a story of the blood, sweat and tears of our Suzuki Marine engineers in their pursuit to find the “Ultimate” technology and shape the wishes of Suzuki Marine members all over the world.

This is a story of the masterpiece created through the 50-year history of Suzuki outboards and a story of how the DF350A (Geki) came to become the “Ultimate” flagship.





Suzuki's "Way of Life!" is the heart of our brand - every Suzuki vehicle, motorcycle and outboard motor is built to create excitement so customers can enjoy everyday life.



## SUZUKI LEADS IN AWARD WINNING INNOVATION



The Innovation Awards (recognizing technological innovation) granted each year by the NMMA (National Marine Manufacturers Association) are considered among the highest honors in marine technology. Of the new marine industry products in that year, they are awarded to "a product that shows technical leadership, is practical and cost-effective, and is truly beneficial to the consumer."

Starting with the DT200 Exanté in 1987 and extending to the DF30A/DF25A in 2014, Suzuki outboard motors have received this Innovation Award a total of eight times. Seven of these awards have been for four-stroke outboard motors, which is the largest number of awards in the engine category of this industry.

### AWARDED PRIZES

1987: DT200 Exanté / 1997: DF70 & DF60 / 1998: DF50 & DF40 / 2003: DF250 / 2006: DF300 / 2011: DF50A & DF40A / 2012: DF300AP / 2014: DF30A & DF25A

Please read your owner's manual carefully. Remember, boating and alcohol or other drugs don't mix. Always wear a personal flotation device when boating. Please operate your outboard safely and responsibly. Suzuki encourages you to operate your boat safely and with respect for the marine environment.

Specifications, appearances, equipment, colors, materials and other items of "SUZUKI" products shown on this catalogue are subject to change by manufacturers at any time without notice and they may vary depending on local conditions or requirements. Some models are not available in some territories. Each model might be discontinued without notice. Please inquire at your local dealer for details of any such changes. Actual body color might differ from the colors in this brochure.



**SUZUKI MOTOR CORPORATION**

300 TAKATUKA-CHO, MINAMI-KU, HAMAMATSU CITY, JAPAN 432-8611

99999-C1043-001 DF350A PRODUCT INFORMATION © Printed in Japan 1705



## Chief engineer talks about development story

Since the development of the world's first 300 horsepower 4-stroke outboard in 2006, DF300 has been brought up and trained by our customers to evolve into DF300AP, which is equipped with the Suzuki Lean Burn Control and Suzuki Selective Rotation systems. DF300 has been praised by customers for the reliability and durability, but meanwhile, there were many customers who demanded more power.

In the development of DF350A, the scene I imagined first is our customers using DF300AP and shouting "Wow!" Suzuki's V6 engines have a narrow 55-degree bank angle, so the minimum interval is 27 inches when rigging two outboards. "Can you mount this engine on my boat?" "No. The engine got bigger as the horsepower increased. So, please buy a new boat." Such a response will let our fans down.

The concept is a 350 horsepower engine that DF300AP users can rig easily on their boat. Then, V6 with a narrow 55-degree bank angle becomes our unavoidable condition. We planned to keep the bore pitch 108 mm to be the same as our reliable and durable DF300AP. This was the starting point of development. There were many challenges to overcome.

First priority is power output. For that purpose, it is common to increase the displacement, but it decreases fuel economy and makes it difficult to realize the bore pitch of 108 mm. After repeated development test, we found that with displacement of up to 4.4 L, we can keep the engine as small as DF300AP. The layout was made possible, but to output 350 horsepower, the engine must produce 80 horsepower per liter. DF300AP has already achieved 75 horsepower per liter, but 80 horsepower per liter was uncharted territory for us. To achieve this, in any case, we must improve the combustion inside cylinders. Mr. Saiga lowered the intake temperature by means of a direct intake system with a dual louver to fulfill the requirement for more power. Mr. Achiwa optimized the shape of the combustion chamber to achieve the compression ratio of 12.0 with an outboard for the first time. I'm sure you will be excited at the sound of Suzuki from the dual louver.

What about performance? Ordinary small displacement engines take longer time to start planing than large displacement engines. They also cannot accelerate sharply on demand. Mr. Sugiyama solved this problem by optimizing the shape of the gear case and using a contra-rotating propeller. You shall experience powerful acceleration you wouldn't expect from a small displacement engines.

Meanwhile, we achieved the fuel economy comparable to DF300AP thanks to the small displacement and lean burn control. Although using the same 55-degree bank, DF350A reflects 10 years of evolution in every detail. Even a single head bolt is newly designed. Suzuki outboards have been brought up by customers and continue to evolve at this time as well.

We have kept you waiting for a very long time.

We're proud to say it's finally here. Please experience Suzuki's flagship model, which is worthy of being called the ultimate 4-stroke outboard.